

NHBG Newsletter

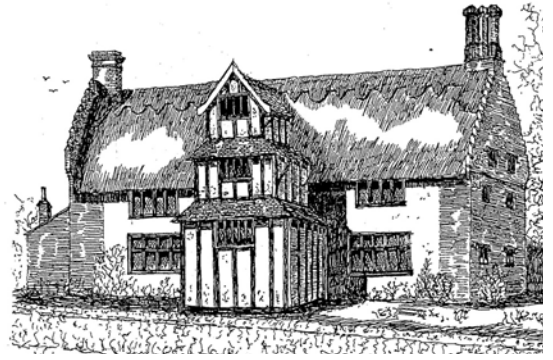

Autumn 2009
Non-Members: £1.00

Norfolk Historic Buildings Group

NUMBER EIGHTEEN
www.nhbg.org.uk



NHBG preparing to invade Barningham Hall approaching by the west facade. The early seventeenth century house has unusual double dormers. The oriel window protruding from the south face was an introduction by the Reptons in the early nineteenth century.

Contents

Chair	2	Vernacular Architecture Group	14
Tacolneston Project: NHBG Journal No 4.....	2	Tacolneston Project	15
Pastures New: Tydd St Giles and Wisbech.....	3	Norfolk Rural Schools Survey.....	16
Fifteenth-century piety in the Glaven valley	4	New NHBG Website. www.NHBG.org.uk	16
Possible Columbarium at St Nicholas, Blakeney.....	5	A Digest of Buildings Visited Since March 2009	17
The Beccles Day Saturday	6	Annual General Meeting.....	17
Leman House, Beccles	7	Gressenhall History Day May2009.....	18
Castle Acre: Castle and Priory.....	8/9	Book List.....	18
Clay Plain Tile Roofs	9	NHBG Committee	18
Barningham Hall, Matlaske.....	10/11	Recording a Timber-framed Building Saturday 12th September 2009	19
Sunnydene, Three Hammer Common, Neatishead.....	12	<i>Do please sign up: we need you</i>	
Hall's Lane Barn, Suffolk	13	Winter Events 2009/2010	20
Editor.....	14		

CHAIR

Welcome to the eighteenth edition of the Newsletter of the Norfolk Historic Buildings Group and to a fascinating summary of the Group’s work over what has been another busy summer. Dominic Summers, as the summer events secretary, has overseen another very successful programme of visits and my thanks go to him, and to those who assisted in making sure these visits went smoothly - in particular the owners of the various properties concerned. Without them, we wouldn’t have a programme at all!

There are two developments to which I would like to make special mention. The first concerns the development of our website. As some members will recall, we secured £5,000 of funding from English Heritage in 2008 to up-grade our website which was looking rather tired. This money has been spent by commissioning a specialist company called Internet Geeks to carry out a root and branch redesign of the site, including the development of a fully searchable online database. Work on the design is almost complete and we are now in the process of adding material to the underlying structure. This is an exciting development and it should ensure that the NHBG website is an enormously valuable resource for researchers from all over the world. I am very grateful to Jackie Simpson, who has taken on the demanding role of overseeing the redesign of the site and liaising with colleagues from Internet Geeks. Watch this space!

The second is the publication of the Tacolneston Project. This represents the culmination of three years work and more than 30 members of the group have been involved in its production. I believe it is the most impressive publication produced by the Group so far, and constitutes an important addition to the literature on Norfolk buildings and on vernacular architecture more generally. I would like to take this opportunity to congratulate all of those involved in the Tacolneston Project - especially Sue and Michael Brown who coordinated the recording process, and Robin Forrest who did the lion’s share of the editorial work on the text. It was lovely to see so many NHBG members, as well as members of the local community in Tacolneston, at the launch of the journal back in July - a wonderful evening was had by all!

A number of long-term projects are currently underway - Ian Hinton and Robin Forrest continue their research on church arcades in Norfolk, whilst Susanna Wade-Martins is co-ordinating a fascinating project recording and researching the county’s historic primary school buildings. The committee have decided, however, that it will leave a year’s gap before starting out on another intensive recording project like that at New Buckenham or Tacolneston - if you have strong views on what form the next long-term project should take, or where it should focus its activities, do let us know!

Finally, thanks are again due to all those who helped with organising another very well attended AGM (this time in Beccles) and to Rosemary and Alayne who have edited another superb Newsletter. Enjoy!

Adam Longcroft
Chair, Norfolk Historic Buildings Group
 September 2009
 a.longcroft@uea.ac.uk

Tacolneston Project: NHBG Journal No 4

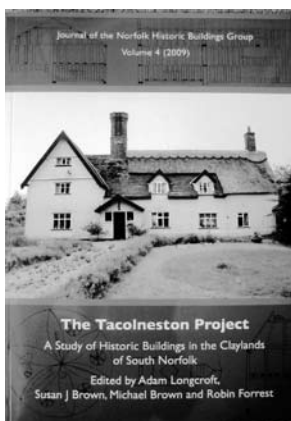

The work at Tacolneston is now complete and has been summarised in NHBG Journal No 4. This contains essays on the landscape context of the historic buildings and some documentary evidence, a full gazetteer, and the dendrochronological analysis.

Copies can be obtained from Ian Hinton, The Old Rectory, Barnby, Beccles, NR34 7QN together with a cheque (*Norfolk Historic Buildings Group*) to include postage of £3.00.

Copies will be available at winter meetings.



- Journal No 4
 - Member£10.00 + £3.00 Postage & Packing
 - Non member£12.00 + £3.00 Postage & Packing
- Journal No 3 Case Studies from Norfolk...£ 8.00 + £3.00 Postage & Packing
- Journal No 2 New Buckenham£ 8.00 + £3.00 Postage & Packing
- Journal No 1 A Research Agenda.....Free to all new members (limited stocks)

Pastures New: Tydd St Giles and Wisbech - July 11th 2009

Ruth and Euan Pearson

We were delighted to have the chance to visit a little known area of East Anglia and find that for other members too it was a voyage combining mystery and discovery. Tydd St Giles near the River Nene on the Lincs/Cambs border was our first port of call: we were told that the origin of Tydd was either tide/tidal or from stith meaning staithe.

Bob Turner showed us round The Old Church House, which in historic records is called Old House in New Field. When he bought it eleven years ago, it was two cottages, part sixteenth century and part seventeenth century, with a Georgian addition and a twentieth century wooden extension. He



spent two years working alongside builders to “conserve” it. As an active member of The Society for the Protection of Ancient Buildings he has spent much of his life finding interesting buildings and bringing them back to life. During the conservation period he had four open days for the community, believing he is only the current caretaker and the house is part of village history.

This long brick building has four large fireplaces - two up and two down - and Bob thought that it had all the features of a Church Ale House, which might have been part of an ecclesiastical complex used for meetings and a place to stay for visiting dignitaries. There is no record of it ever being a rectory. While owned by the church the front façade was Georgianised. In 1820 it became four poor houses until sold by the church in 1860. Interesting features include a spiral staircase around a mast-head newel post, lovely wide oak floorboards and beams and a chamfered brickwork fireplace. As a Grade II listed building on three floors, there is evidence of thatch, slate and Norfolk pantile on the roof: sadly it now has concrete tiles.

Across the road is the thirteenth century church of St Giles built from Barnack Rag with its fourteenth century detached bell tower. The previous one, part of the main building, fell down and was rebuilt on more solid ground. The top stage is late fifteenth/early sixteenth century and despite a large crack in the brickwork, the bells are still rung. In the late fifteenth century



the roof of the church was raised and a new clerestory was built, leaving the tops of the thirteenth-century original windows clearly visible.

The chancel, originally 50 ft long by 20 ft wide, was badly damaged in a gale in 1741 and later pulled down. Further extensive restoration took place in 1868 under Canon John Scott, whose brother Sir Gilbert Scott directed the work. The original plan is displayed in the church. Amongst the many treasures are a fine silver chalice inscribed “FOR TED SENT GYLS 1570” and a magnificent organ.



After welcome refreshments in the Red Lion we were guided around Wisbech, by Roger Powell, a member of the Wisbech Society, admiring the Georgian houses along North Brink. One of the finest examples, Peckover House, with its lovely gardens, was bequeathed to the National Trust in 1948. No-one seems to know why or for whom it was originally built.

Another fascinating area of the town is the large site of the vanished Wisbech Castle, which now boasts one of the oldest purpose built museums in the UK housing a treasure trove of exhibits, including the original manuscript of Dickens’s “Great Expectations”, and tributes to Thomas Clarkson – a slave trade abolitionist. Nearby is the fine circular “double Crescent” developed by a local builder Joseph Medworth in 1816.

Many thanks to our guides and especially Dominic for a memorable day where many questions were answered but a fair amount of mystery remains.

Next day Elizabeth Rutledge kindly informed me that ‘Tydd’ or ‘Ted’ means a mound, as in bedding hay. In the Domesday landscape of the three Tydd parishes a molehill would have been noticeable in such flat terrain! Ed.

Fifteenth-century piety in the Glaven valley

Ian Hinton

On 12 May under the guidance of Gerald Randall and Neil Batcock, twenty of us visited Cley, Wiveton and Blakeney churches in the Glaven Valley, each of which was obviously extremely wealthy before the valley silted up and left Cley and Wiveton landlocked. There are many similarities in terms of the investments made in the churches in the fourteenth and fifteenth centuries, but with completely different approaches.



Cley church (*above*) is large which in itself shows evidence of enormous investment over the centuries. It had a new long chancel in the late thirteenth century, in common with many other churches after the Fourth Lateran Council of 1215 which altered the mass ritual requiring more space and more celebrants. There are two transepts which were laid out at this time but were completed later. The south window in the transept, the one which faced the mariners on the river and quay, was the show window and had so much tracery in it, that the arch at the top is shaped like a horseshoe in order to fit it all in. Much of the masonry carving is thought to be by John de Ramsey and his workshop, as are parts of the cloister at Norwich cathedral, confirmed by the lions with the characteristic ‘back-combed’ manes. The grand porch with a free-stone front is dateable to 1405-1413 with references to Anne of Bohemia.

Despite all the obvious investment here, there are several oddities that show up in the building. Returning to the chancel, it is unique in that it is narrower than the chancel arch, requiring some odd building fudges to fit the two together. In addition, the chancel, tower, nave arcade piers and aisle walls are all on slightly different alignments, raising the possibility that there were originally two small churches built end to end (as at Stiffkey), and that the tower of one and the chancel of the other were connected by a new long nave.

Wiveton (*top next column*) is directly opposite Cley across the estuary, in direct competition presumably visually as well as commercially. Again there is lots of evidence of investment in the church – extensive knapped flushwork using white flint, which shows it is early, rather than the black flint of later work. Here too, the chancel was lengthened and raised. The mouldings round the doors are similar to those at St John Maddermarket, Great Cressingham and the south porch at Beccles, which can be dated to 1440-1450. The



complex arcade piers between the nave and the aisles are probably of about 1420 and are similar to those at St Andrews Hall, but with a unique extra flourish.

Blakeney church has one unique architectural feature, another one almost unique and a third which is very unusual. The church has two towers, a second one is built at the east end of the chancel, of which more in next article. The east wall of the chancel contains a window which is made up of seven individual lancets (*below*), seen elsewhere only at Blackfriars in Kilkenny in Ireland. The last feature is the stone vaulted chancel ceiling which is dated to around



1240 or 1250, with stone bosses carved into rare stiff-leaved forms. The arcade piers are the same form as at St Andrews Hall in Norwich and New Buckenham and are probably late fourteenth or early fifteenth century.

We saw three churches, close together, but where the residents had different approaches towards expressing their piety. Each church has had large amounts of money spent on it, but was used for improving, renewing or enlarging different aspects of the building. One slightly odd result is that of all the money put into the buildings, the tower from an earlier phase of the building was retained at Cley and Wiveton and only at Blakeney did residents in the fifteenth century choose to invest in the main tower in addition to the rest of the church, whereas at so many other villages and towns across the county during this period, new towers were soaring upwards.

Possible Columbarium at St Nicholas, Blakeney 10 May 2009

Ian Hinton



John McCann who spoke to the group in 2006 (*see Newsletter No 13*) about Dovecotes, is investigating Columbaria – the keeping of pigeons in churches. He has found 33 churches so far, and late Victorian reports of one at St Nicholas, Blakeney were investigated as part of our visit to the church in May.

The chancel at Blakeney church is approximately 10m by 6.5m internally. It has a stone vaulted ceiling, probably thirteenth century, with a large void between it and the roof. This is entered by a stone spiral staircase at its north eastern corner accessed from a door in the chancel which is hidden behind a stone and wooden reredos across the width of the east end. The stair tower is built of flint with freestone quoins, has no external access and is lit by 4 small lights, now glazed. Access to the remainder of the tower is restricted, but contains no evidence of a bell or lights or fires – all suggested as possible uses for the tower as a navigation aid to seafarers. Apparently the upper parts of the tower are “fragile” and could not support a swinging bell of any size.

The current roof appears to be a nineteenth century replacement of a similarly shaped roof. The principal rafters are cranked by about 60cm, leaving clear headroom of almost 2m. At least two of them are pine and three of oak. It is assumed that the two pine rafters replaced earlier oak ones. The drawing of the church by Ladbroke in c1823 shows the chancel roof to be missing: he is normally thought of as being architecturally fairly accurate, so it is possible that his drawing was done during the roof’s replacement.

There is a short door at the west end of the roofspace which opens high up into the nave behind the current roof, and there is a window of a similar size in the east end.

There is strong evidence for an even earlier roof of a much steeper pitch – as a scar, externally on the east end of the nave; internally in the fabric of the north and south walls of the chancel where the fabric changes from small flint cobbles to larger cobbles with a high proportion of re-used freestone; and less obviously in the change in quoining on the east end of the chancel and the truncated chancel buttresses. The consensus on the day was that these changes were probably fifteenth century and all point to a roof with eaves about 1.5m lower than currently and a ridge almost 2m higher (almost as high as the current nave roof). Unfortunately the parts of the external walls of the chancel which are not freestone are rendered in what appears to be cement render, so hiding any further evidence.

Internally, the ‘fifteenth-century’ wall heightening contains 6 putlog holes in a horizontal line in each wall, approximately 2m apart. Much of the rest of the wall was made of re-used freestone, some from earlier windows and arches, but there is no evidence of blocked nest holes, and no access for birds other than the east-end window, which appears to be contemporary with the wall. The east and west walls are lime rendered so it is not possible to see if there were once nest holes there. If the columbarium was part of the earlier roof arrangement, then there would have been almost no north and south walls above the level of the vaulting and considerably less space available than in the later configuration.

I don’t believe that further detailed investigation would alter this conclusion.

The Beccles Day Saturday 27 June 2009

Alayne Fenner

This year, unusually, our AGM was followed by the Summer Party, both held at Beccles Museum, and preceded by a tour of Beccles town. The day dawned clear and bright, members assembled in the car park by the Waveney at the north end of the town. Meanwhile, we of the catering contingent, having unloaded the provisions, met them there via the ancient Puddingmoor, that runs under the cliff by the river. Ian handed out town maps, helpfully colour-coded, marking the probable boundary of the long narrow Saxon settlement and the Old and New Market places, each with its church. The magnificent St. Michael's stands high above the cliff and dominates the much-encroached upon New Market, (there was a wedding in progress so we only peeped in) while the site of the early St. Peter's, alongside the Old Market, is now heavily disguised as an eighteenth-century Gothick house, its curved apse projecting into the Puddingmoor junction with Old Market (*see p.19*). Apparently geophysics done in the garden showed arcades and walls.

We started up Northgate street where I well remember the appalling traffic congestion before the 1983 bypass; now we could saunter along in comparative peace. The street is lined with many fine houses showing a multiplicity of gables, both plain and shaped Beccles is, amazingly, nearer Holland than London! Some of the Georgian facades are applied to earlier, possibly timber framed, buildings, (as we also saw at Harleston, *Newsletters 10 & 13*) and there are other, humbler, houses which once had outbuildings stretching down to the river behind. There are several Scores, or passages, running down to the staithes from the street (as at Lowestoft) with formerly warehouses, tanneries and pubs.

We arrived back at the Museum (Leman House) where Ian led a tour of the building while tea was prepared - the now-traditional cream 'n' jam scones! - followed by the AGM and, finally, the Summer Party drinks and eats, all in the lovely garden perched high above the river with views across into Norfolk. It had been a rich, full day.



Gables galore!
 Left: 18 Staithe House: early 17thC oval windows & pediment
 21 Blyburgate: flat top
 41 Northgate: advertisement
 Above: semi-circular tops
 Flemish House, Northgate
 20 Hungate
 12 Newmarket
 Oswald House (2): Georgian facade
 27 Northgate and Newgate/Old Market (1694 dated): triangular
 Newgate: flamboyant gable, Georgian front.
 (photos: Ian Hinton, Rosemary Forrest)

Leman House, Beccles Ian Hinton



although it is not known who built it, or what it was initially used for. Comprehensive documentary records exist from 1632 onwards with detailed accounts for the work of maintenance and improvement to the building, but even then there are unanswered questions as to why some of the strange work to the building (such as lowering the floor levels at one end requiring much expensive underpinning of the walls) was ever done at all.

The equal bay spacing in the roof structure strongly suggests that the building was originally built for a non-residential use, as does the lack of internal partitions in such a large building. The distance from the shops in New Market would tend to put a speculative shop development out of the question, although the five blocked doorways in the rear wall do imply that the ground floor at least may not have been intended for single occupation. It is also unlikely to have been a guild hall, as these always have a large room, often just a single room and often upstairs, but some of the current partitions at both ground- and first-floor level are original, and there is other evidence of original partitions which have been replaced. It was also suggested that it may originally have been almshouses, although with three storeys, and only a few internal partitions, this also seems unlikely. This leaves the possibility that it was originally built as a school, and that Sir John Leman used this building as a school because of its suitability.

Normally, documentary research, or a detailed archaeological survey can point to a building date or the purpose of the building, but not here. Even the comprehensive accounts kept by the school governors for nearly three centuries cannot explain all the work done and still leave much to be established.



Top:
Front now flint chequer-work skin

Below:
Rear brick wall showing evidence of alterations.

Leman House is a Grade 1 listed building of the mid sixteenth century, which was used as a school, endowed by Sir John Leman, from 1632 until 1908. John Leman was a local man who rose through the ranks of the guilds in London, ultimately to be knighted and to become Lord Mayor of London.

The walls of Leman House are of brick, with a later brick and flint chequer-work skin applied to the front wall. The roof has a series of 10 queen-post trusses still in their original order and with a fine set of chiselled carpenter's marks. Strangely, other joints in the roof have scratched carpenter's marks numbered in the opposite direction but appear to be contemporary with the joints with the chiselled marks, rather than from a later rebuild. The building is first mentioned in documents in 1559, as earlier local documents were lost in a fire,



Chiselled marks on roof timbers.



Queen Post, purlins and arched braces.

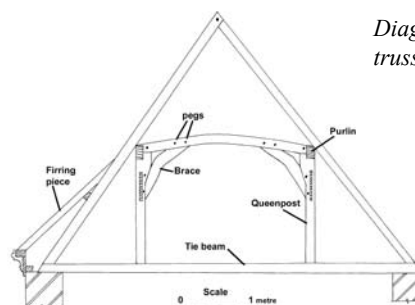

Diagram of Queen Post roof truss.

Castle Acre, Wednesday 3 June Dominic Summers

Twenty members gathered on the little green in what is now the centre of Castle Acre under grey skies to meet our distinguished guides, Dr Rob Liddiard and Prof. Sandy Heslop of UEA. Rob outlined his plan for the morning's tour of the castle and town, after which many of us were glad we had decided to wear our stoutest shoes.

We started at the back of the castle where we were given a number of very useful handouts and a brief description of the topographical context of the site, its relation to the surrounding field patterns and its strategic location at the confluence of the Peddars Way and the River Nar. An examination of the masonry of the curtain wall and its buttresses revealed different building phases culminating in a raising and strengthening of the wall in the second quarter of the twelfth century. We proceeded through the Bailey Gate into the site of the twelfth century planned town around which some of the original earthworks of the town wall are still standing. Then into the castle where Rob and Sandy interpreted the material remains. The main castle building was substantially revealed by a very large archaeological dig in the 1970s and what is visible shows a large two celled building with flint walls, erected in the late eleventh century, probably on the site of a Saxon aristocratic hall complex. Interestingly, there is evidence of windows at ground floor level, which suggests that the building was not constructed with defence uppermost in mind and has led to it being referred to as a grand country house. This phase of



View south from castle mound towards later medieval house and Peddars Way. (Photo: Rosemary Forrest)

construction was carried out by William de Warenne, 1st Earl of Surrey, who fought at Hastings with William I and was almost certainly the richest man in the kingdom after the king himself.

In the second phase, the front half of the building was abandoned and filled in and the walls of the remaining part were doubled in thickness to support a greatly increased height. The building seems to have been converted into a very tall tower keep, similar, perhaps, to Hedingham in Essex. The surrounding earthworks and curtain wall were raised at this time too, creating a very impressive ensemble, and the original route of the Peddar's Way was blocked and a new route looped through the new town and along a ridge south of the castle. Rob was convincing in arguing that all this twelfth century work was carried out with the main aim of creating a dramatic approach to the de Warenne's East Anglian seat, rather than making the castle defensively stronger.

After lunch we explored the Priory with Sandy as our principal guide. This, too, was a foundation of William de Warenne in the late eleventh century. It was a Cluniac daughter house of the earl's Lewes Priory and was laid out on a typical Cluniac ground plan with an apse echelon at the east end. The elevation is more typical of earlier Norman churches such as St Etienne at Caen, but the most remarkable aspect is the complexity of the pattern of mouldings and decoration in the pier responds of the nave arcade. East of the crossing this heterogeneity was achieved through the use of variegated materials, principally alternating bands of limestone and carstone.

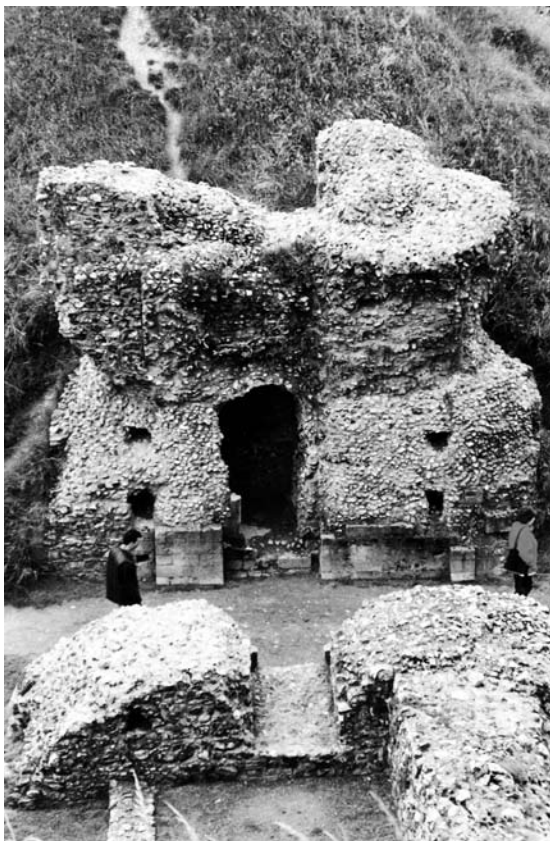

Castle wall and bailey gatehouse with alcoves; some stone facings remain. (Photo: Rosemary Forrest)



Priory church aisle piers used variegated materials for decoration, possibly with a Persian influence. (Photo: Rosemary Forrest)



Castle Acre Prior's lodgings viewed from the north; it lies adjacent to the west end of the priory. (photo: Colin King)

The conventual buildings are remarkably complete when one considers that much of their material can be found in the walls of the houses in the town. There was some debate amongst those present about the ridge running the length of both walls in the monks' dormitory and whether it could have been a ledge to support the beds. Everyone agreed, however, on the magnificence of the latrine block; someone mentioned that the monks must have been a very Regular community!



Castle Acre Priory ruins seen from the north. (photo: Colin King)

We finished by having a look at the wonderful Prior's lodgings and Rob showed us some of the hydraulic engineering and agriculture of the Priory community.

Although a number of our party had previously visited Castle Acre, nobody had ever received such thorough and perceptive insights into the place. We were left with a very good idea of the buildings in their context and of how the castle, town and Priory meshed together in a fine example of Norman aristocratic planning and magnificence.

We were delighted to receive the following e.mail from Dirk Bouwens. Ed.

Clay Plain Tile Roofs Dirk Bouwens FRICS

“Here is a short article about plain tiling on roofs. There is some sort of discussion about whether a tile is layed or laid like an egg!”

The house that I was brought up in has clay plain tiles on the roof slopes which may have been put on in the early 1800s, except the north slope which has slates. The tiles were laid on narrow riven battens fixed with iron tack like nails. Each course of tiles had second cut hay that was layed on top of the courses of tiles. Second cut hay is grass that has regrown after the hay crop has been gathered. The second cut hay is mainly composed of the leaves of the grass, and is soft and pliable. It is there to prevent rain and snow blowing into the roof void. This grass may have been there for about two hundred years. When this roof was tiled again white sarking felt was used and when the weather was windy the sarking could be heard to make a crackling noise.

Sarking felt is a nuisance because it masks the view of the under side of the tiles and battens. Sarking felt prevents debris from blowing into the roof space and keeps blown snow and rain out of the roof space. The alternative solution of this problem is to put fibre glass quilt between the tiles. The fibre glass quilt needs to be cut into strips and to be split through its thickness and dipped in water so that it is handled more easily. This wet fibre glass quilt is laid on the top third of each course of tiles and beneath the lap of the next course of tiles so that the fibre glass cannot be seen. This was done to a Grade One house, Breckles Hall, in Norfolk.

The result is that sufficient air can pass through the tiles while keeping snow and rain from entering the roof space. The fibre glass quilt is not visible. The tiles would traditionally have been laid in lime mortar which may or may not have any hair in it. Lime mortar may not allow as much air to enter the roof.

There was no trade of tiler in early days. The bricklayers would complete tiling the roof when the chimneys had been completed. Tiles were laid like bricks with lime mortar between them and I have seen tiles with no pegs nor knibs, laid with lime mortar between them for twenty or so courses, before a peg was put in.

The appearance of the roof is improved with the use of chestnut or oak lath battens. These are obtained from the suppliers of laths for ceilings and walls. Splitting each lath in two will make a traditional tiling lath and may make problems with the nailing. Galvanised clout nails will fix the battens and hold the battens when they split. The battens despite their size are very strong because the grain is parallel. I have seen special nails used to fix the narrow battens. The nails are shaped as hooks and are driven into the rafters just below the battens. These hooks are used in game larders to hang the newly shot birds.

When the roof is tiled with hand made plain tiles on riven battens, it takes on a three dimensional appearance which is very attractive.

Barningham Hall, Matlaske. 22 July 2009

Rosemary Forrest and Alayne Fenner

The Hall was approached through the village of Matlaske where the southern entrance to the park was guarded by a delightful 'Picturesque' cottage of c1813 by Humphry and John Adey Repton. It was their re-designing of the park, probably following a Road Order of 1815, and driveway which provided us with an angled view of the south and west aspects of the hall at just the right moment for its site and improved design to be appreciated, the frontal attack of an avenue being no longer fashionable.

The hall is a large red brick mansion with stone dressings, built for Sir Edward Paston in 1612, and was finally acquired by Thomas Vertue Mott in 1785; the present owner Thomas Courtauld is a descendant. Of the early house the five-bay west façade has a handsome porch with polygonal angle buttresses. The other striking feature of the west façade is the two-storeyed, pedimented, dormers which make the house look very tall for its width.



Diagonal skintling marks, mark of pre-mass production, on the brick polygonal angle porch buttresses.

The Reptons, many of whose original drawings and plans were on display for us, made alterations to the south face, porch vault, and the east face in the years around 1810. The work by the Reptons is fairly well documented and Humphry used it as an example in his Fragment IX: Concerning Windows where he talks about "preserving the east front most scrupulously", although he did change the glazing when he added an extension to the south elevation. He felt that the house "did not contain one room that was comfortable or of a size adapted to our modern style of living". It was the early seventeenth century rooms which the Group tried to locate amongst the later internal changes.

The plan of the original ground floor reminded some of us of Kirstead Hall, south Norfolk (c.1600) where a small room, and a corridor, acted as a buffer between kitchen and hall. Whilst at Kirstead the main stairs led off the hall, at Barningham the original principal stairs appeared to lead off this corridor near the kitchen, unless the hall was at the north end and the small room was added later. Unfortunately the exterior windows, in their symmetry, give no evidence as to the status of the interior space. These dog-leg stairs were

wide and impressive and, interestingly, went all the way to the top floor by which time they had become winders, but still wide. It was questioned whether they might have led to a gallery along the top floor but the evidence is hard to find. This is because the house was reorganised and re-roofed in the nineteenth century to what Mark Girouard has called the "Moral House" with separate access and

accommodation for male and female servants. In the corner of this upper staircase is a corner washbasin with two taps which were perhaps added at different times, the later one possibly when hot water became available to the servants.

Interestingly, as well as Repton's kitchen extension, a gun room had been added to the east side of the hall, access to which was available from the seventeenth century farm yard and its nineteenth century service buildings.



Early winder staircase with later wash basin.



East facade with crowstep gables. Repton's kitchen is behind the greenery and the gun room to the right.

There was little doubt that the magnificent series of 'enfilade' cellars were part of the original house. It was fascinating to see the nineteenth century passion for shooting in evidence over the early dairy shelves in the north cellar; each side has a strip of wood with holes along the bottom and the days of the week, except Sunday, painted on them so that the cooks knew how long game had been hung. There were

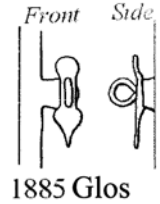
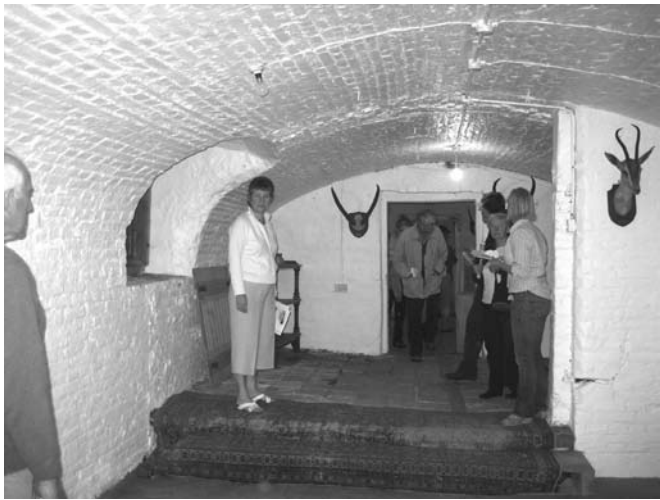

The cellars of Barningham Hall. The window catch is in the large room photographed. The game larder is at the far, north, end. Linda Hall's drawing of a similar catch found in Gloucestershire.

two sets of stairs, one of which went from this cellar to what was presumed to have been the kitchen, the other from the later wine cellars to the principal entertaining area. There was an unusual window catch which it is thought might have been early but a hunt through Linda Hall's *Period House Fixtures & Fittings* revealed one in Gloucestershire in 1885.

Little has been said in this report about the principal rooms of the house as these are well recorded but it was noted how keen John Thomas Mott (1809-84) was to establish his lineage by the display of arms stretching back to the Paston family. The frustrations of endeavouring to seek the early

house, its plan and circulation pattern overlaid by eighteenth and nineteenth century changes brought forward many musings which sadly were not conclusive. This however leaves scope for a further visit.

Before leaving the park some of us visited St. Mary's church, which has been a part-ruin since the seventeenth century. The tower fell to the west and the nave and south porch are roofless and crumbling. The fourteenth-century chancel was restored and enlarged in 1830 by John Thurston Mott, who built a large entrance lobby and a gallery for the staff within the original chancel arch. In 1873 the interior was again thoroughly restored by his daughter-in-law. The elegant ogee-arched triple-stepped sedilia and piscina perhaps indicate the quality of the lost church and there is some good glass, especially the glowing coat of arms of Carolus Rex in the east window. What is most unexpected, and unusual however, is that the shafts of the ruined south doorway are standing on two huge blocks of ironbound conglomerate.

Our grateful thanks are due to Tony Wright for masterminding the day and to Amelia Courtauld for so kindly allowing us to roam through her home and garden. As a postscript it should be added that we all enjoyed our post-visit lunch at The Saracen's Head.

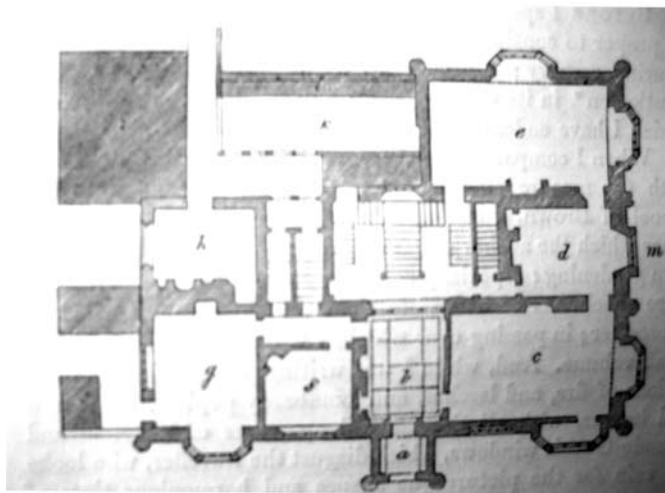

*Above
Principal floor as shown in J C Loudon's
Observations on the
Theory and Practice of
Landscape Gardening
(Edinburgh, 1804-6)*

*Left
Glass in the east
window of St Mary's
Church: Carolus Rex.*

Bibliography

- Ashwin, T, and Davison, A, (eds), *An Historical Atlas of Norfolk*, 3rd Ed., 2005, Phillimore, CUP, Cambridge
- Bryant's Churches, 1900
- Girouard, M, *Life in the English Country House*, 1978, Yale
- Girouard, M, *The Victorian Country House*, 1973, OUP
- Grigor, James, *The Eastern Arboretum or Register of Remarkable Trees, seats, gardens, etc in the county of Norfolk*, 1841, London, Printer John Stace, Norwich
- Hall, L, *Period Houses Fixtures & Fittings 1300-1900*, England's Living History, Countryside Books, Newbury, 2005
- Repton, H, *Fragments on the Theory and Practice of Landscape Gardening*, 1816.
- Williamson, T, *The Archaeology of the Landscape Park: Garden design in Norfolk, England, c. 1680-1840*, BAR British Series 268, 1998, Archaeopress, Gazetteer
- Winkley, George, *The Country Houses of Norfolk*, 1986, Tyndale+Panda Publishing, Lowestoft
- www.heritage.norfolk.gov.uk: NHER Nos: 6569, 30431, 39616, 12170, 44526, 44528, 44547, 44548, 44549,

Sunnydene, Sow's Loke, Three Hammer Common, Neatishead, Norfolk. Susan and Michael Brown

We recently visited this thatched house (Fig. 1) at the end of Sow's Loke and found a dated building exhibiting features that related to a much earlier dwelling. The east and west gable walls both have chimney stacks with rebuilt tops copying the original form with offset drip courses. The front is faced in flint; the knapped and pebble flint is roughly in courses with galletting and some random brick headers. The centre window has been converted from a doorway (pre-1976; the date of listing) and the wall below infilled with pebbles. Above the windows there is evidence – in the size of bricks and in the pattern of the flints used – for a roof raise. Bricks have been used here to give the date

1816 and the initials 'I H'. The north and south walls are of clay, approximately twelve inches thick. Protruding through the rear wall into the outshut at the original eaves level are the ends of the tie or anchor beams (Fig. 2). Each end has a mortice for a face peg. It is probable that these did not have associated posts, as shown in the drawing from the Council of British Archaeology (No 5 Revised edition) Illustrated Glossary (1996) (Fig. 3), but were inserted through the masonry wall. We have not seen this pegged anchor beam before in a house, though it is familiar from furniture (Fig 4). Has anyone come across other examples?



Figure 1 Exterior view of Sunnydene, Sow's Loke

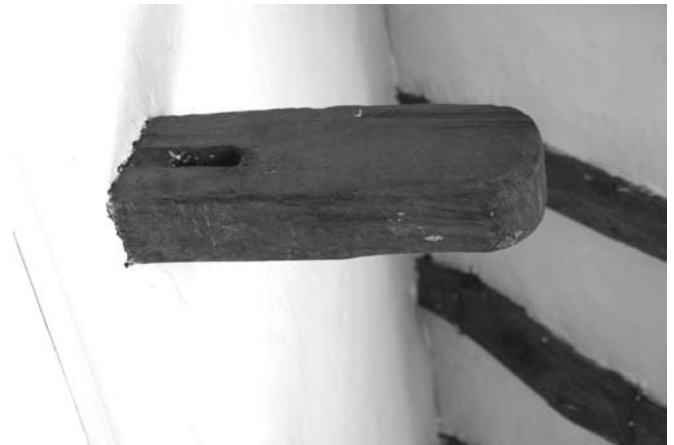

Figure 2 End of the tie or anchor beam at the original eaves level.

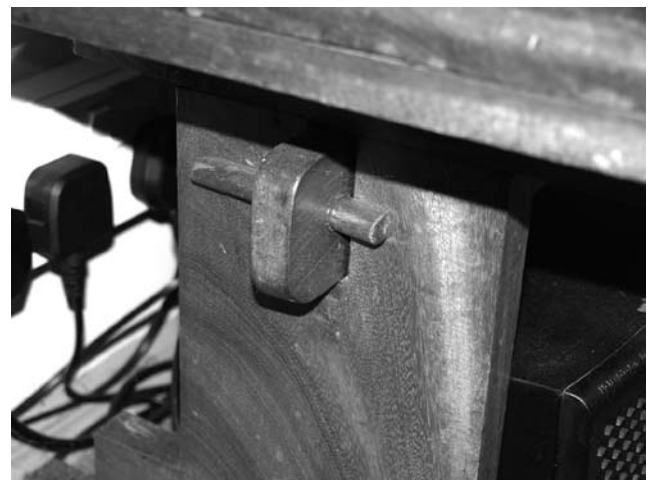
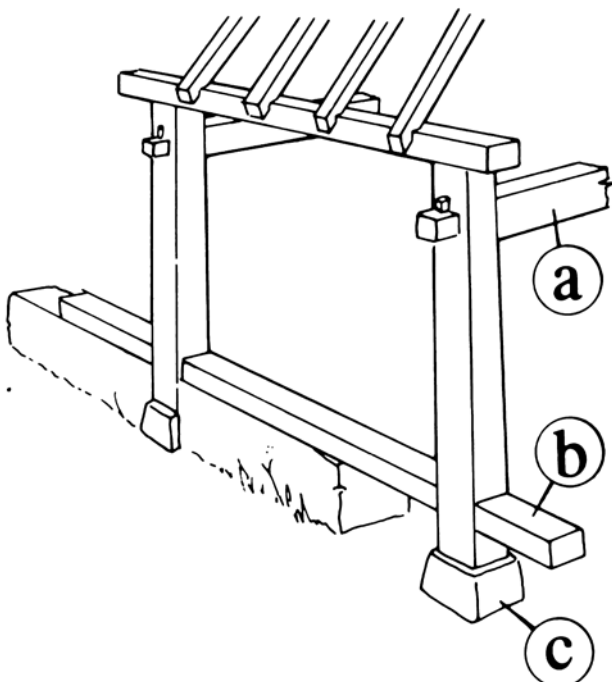

Figure 4 Coffee table with an anchor tie.

Figure 3 Council of British Archaeology (No 5 Revised edition) Illustrated Glossary (1996) (a) Anchor beam; (b) interrupted sill; (c) padstone

Hall's Lane Barn: A Member's Visit to Suffolk with SPAB* Clive Baker



South west aspect of barn.

South east lintel



Norfolk is a county rich in timber frame buildings but close to our border there is what could be described as one of the finest timber frame barns in East Anglia, if not the whole of England!

The 'Listing' details of this Grade II* barn are:

"mid-sixteenth century, six-bay, timber-framed and weather boarded (some areas of wattle and daub beneath). Corrugated asbestos roof, once thatched, half-hipped and gabled at either end. Sets of four boarded barn doors, at bays two and five, on west side. Pairs of smaller stable-type doors on opposite side. Interior: an unusually finely-wrought barn, with some very rare carpentry features. Very closely spaced studding, tension-braced in the gables and at the corners of side walls. The half hipped roof is supported on corner base crucks, a feature found in some houses in Mid-Suffolk in sixteenth century, but in no other instance in a barn. Open trusses each have two pairs of thick archbraces, one close beneath the other, a rare feature in Suffolk (three out of the ten sets are missing). The middle rails in each bay are subdivided by an unjowled storey post. Archbraced collarbeam trusses at half-bay intervals, with heavy principal rafters supported by raking queenstruts from tiebeams. Two tiers of butt purlins with thick windbraces at both levels. A ridge piece (a rare feature for West Suffolk) is clasped by the principal rafters, and is triangular in section. The barn formerly had large doorways on the east side (infilled in eighteenth century) and the eastern [surely western?] doorways were enlarged at that time. Complete eighteenth/nineteenth-century brick floor."

This description fails to convey the impressive nature of the various braces, probably the most noticeable feature of this building. The double arch-braces are visually stunning and very rare for this part of the country and which,



Half hipped end of barn.

according to our guide on this 'SPAB' visit, are a West Country feature and puzzling why they were used in this instance. The quality of the woodwork is truly amazing, the studding being very closely spaced bearing in mind that this is a barn! The house that formed part

of the complex must have been equally imposing but no longer exists though it is thought that timbers from the house were re-used in Hall's farmhouse which is a short distance away. Certainly Hall's farmhouse is not a sufficiently well built house to have warranted such an expensive and impressive barn; the timber framing recently exposed being of a very inferior quality.

Also missing from the 'listing' details is the recently discovered fact that the black poplar weather boarding on the southern half-hipped gable end is original, a rare survival. The other strange feature concerns the doorways, see my comment in the listing details. On this occasion our guide, who was largely responsible for the English Heritage listing, was of the opinion that the eastern lintels, one being shown in my photograph, were later inserts thereby reducing the height of the original doorways; his reason being that there were no relevant peg holes for the lintels or braces in the wallposts and the former were secured by nails. However as there is studding between the lintel and the wall plate, and similar studding mortices on the western wall plate, these, or earlier lintels, must have been originally installed at this level. The effort that would be needed to cut mortices for the studding at some later stage into the in situ wallplate would be enormous; the wood being virtually unworkable due to ageing. The lack of pegs may be due to the fact that the lintels and braces are possibly under compression rather than tension and therefore not really necessary.

Unfortunately this barn is now on the 'buildings at risk' list, not due to any particular neglect by the owner, but because of the inability for a realistic conservation scheme to be developed. The wall posts are now largely unsupported and the barn leans towards the east, in fact it is probably only the finely crafted roof structure that actually allows the building to still stand! Temporary buttresses have been inserted but a long term solution needs to be developed.

Although it is not a Norfolk building, though it is only nine miles from the border, perhaps members may be interested to see if a visit could be arranged. It is certainly a structure worth seeing and perhaps we could even resolve some of those issues concerning its construction! I hope the photographs also 'whet' the appetite of fellow members to pursue the idea of a visit.

**Society for the Protection of Ancient Buildings. The NHBG is fortunate in that it is informed of some of the local SPAB outings and, if spaces are available, are invited to join the visit.*

EDITOR

The Group has had a very successful and enjoyable summer of outings and junketings and our thanks go to Dominic and Ian for their organizational skills - and stamina! The visits that were over-subscribed -and there were several - we plan to repeat next year - and we would also welcome any bright ideas you might have for possible venues for day, or part-day, visits in 2010. My thanks also go to the stalwart scribes who have reported this year's meetings - even sometimes volunteering without pressure!

The report of the Norwich Day to The Green House and The Curat House has been held over until the Spring Newsletter.

We are always looking for copy - please keep up the good work.

Alayne Fenner
Editor, Newsletter
01603 452204

alayne.fenner@btinternet.com



Inspection of a wall at Tydd St Giles

Insurance Cover— all members should be aware of the following:

When involved in an NHBG activity, members are covered by the NHBG Insurance. This covers liability to third parties for damage to third party property, ie the legal liability of the NHBG for any amounts it becomes liable to pay as damages for Bodily Injury or Damage caused accidentally, including legal costs. The excess is £250. The insurance DOES NOT cover 'member to member' liability. That is, if one member accidentally injures another. Most members will have cover on their household insurance.

If a member feels the cover is insufficient for their needs, then it is their personal responsibility to obtain adequate cover.

It is worth pointing out that members have a "duty of care" in looking after themselves and others.

Vernacular Architecture Group

Memorial Essay

Please do not forget this Prize.

The essay must not have been published previously, and if it is under consideration for publication elsewhere this must be stated and details given.

The closing date for entries is 30 September each year, and the award will be announced the following January.

Please send any initial queries, and completed entries with your name and address (including email address if you have one) to: Dr Martin Cherry

66 Moorcroft Road, Moseley, Birmingham B13 8LU

Email: martincherry@btinternet.com

Tel: 0121449 8569

If you would like to discuss your ideas prior to submission, please do not hesitate to contact Martin.

Winter Conference 19-20 December 2009

The Polite Threshold

at Gilbert Murray Conference Centre, University of Leicester.

If anyone is interested in attending please contact:

Rosemary Forrest 01603 742315

NHBG Bursary to attend VAG Conferences

The Committee are keen to encourage NHBG members to attend national conferences and to this end have set up a bursary towards the cost of accommodation and lectures but not travel expenses. Anyone interested in attending conferences should contact Rosemary Forrest on 01603742315; forrest.rosemary@gmail.com

VAG Online Databases

OASIS (www.oasis.ac.uk)

Since 2004 many commercial units have been recording their building surveys on the OASIS Online Form and uploading pdf versions of their reports, which are lodged in the Grey Literature Library hosted by the Archaeology Data Service (<http://ads.ahds.ac.uk/catalogue/library/greylit/>).

The aim of the Grey Literature Library is to make available unpublished fieldwork reports in an easily retrievable fashion. There are currently 3582 reports and this number is increasing.

Recently training on the use of OASIS has expanded to cover non-commercial organisations whose work largely falls outside the Planning Process. Training is being offered to members of the VAG,

Further information on the project is available at www.oasis.ac.uk and Mark Barratt, English Heritage (oasis@english-heritage.org.uk, telephone 01793 414826) would be happy to discuss the project with members.

Offprints Library

Remember that the VAG has a library of offprints of articles on vernacular architecture. Apply to: Geoff Ward, RCAHM Wales, Crown Building, Plas Crug, Aberystwyth, Dyfed SY23 1NJ. Please send stamps to cover the postage.



Tacolneston Project Karen Mackie



At a packed village hall on Thursday 23rd July 2009 Tacolneston parishioners finally got to see the results of a research project into the unique heritage which they are helping to preserve. This was the official launch of the Journal No. 4 produced by the Norfolk Historic Buildings Group about the buildings and landscape of their village. One of the aims of the project was to raise awareness of the importance of their properties in our knowledge of the past, in a wider context to increase knowledge of the styles and techniques used in building vernacular houses in Norfolk.

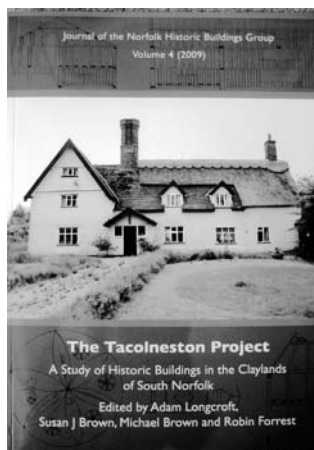

Cottage in Forncett, and began recording a fifteenth century open hall house, The Old House, in Tacolneston. At the same time I gained access for the group to record the little altered Manor House in the centre of the village. These buildings, together with my own, which Michael Brown realised had once had a timber-framed chimney, were enough to persuade the NHBG committee of the virtues of the village for its next dendro-dating project. As a rural village, it would complement and contrast with previous work by the group on the nearby

planned town of New Buckenham.

Sue and Michael Brown and I visited all the buildings in the project and the evidence they provided is reflected in the detailed gazetteer at the back of the Journal. Sue presented a sample of this information at the meeting, concentrating particularly on the dated buildings. Dr Adam Longcroft's talk concentrated on the role of the landscape in the development of Tacolneston and south Norfolk. He drew on the documentary work of Paul Rutledge and Diane Barr and left the villagers with two challenges: where in the village were the medieval market place and the rabbit warren.

These first few buildings set the pattern for what we would go on to discover. As at The Manor House, a number of back houses (or kitchens) survive in close proximity to the main building. Several houses also contain the vestiges of previous timber-framed chimneys. Hill Cottage even has a complete one still in use. Oak/Fiske and Warren cottages, once had both a backhouse and two timber chimneys.

On a personal note, over twenty years ago, when I was at university, Alan Carter gave me my first insight into the fascinating methods of extracting evidence of a building's history. However, I never imagined that I would find myself volunteering to research the buildings of my own village. I have lived here for eighteen years and worked within the village for the last nine. Knowing many of the villagers personally made access to houses much easier and without the generosity of my neighbours the project would never have taken place. Lottery funding made the dendro dating possible but many other members of the group have invested a lot of their free time in the project and to them I am extremely grateful.

Unfortunately we have not managed to date any of the back houses, but we were able to date Riverside Farm in Forncett St Mary which contained a timber chimney. The house, which was built in 1645, shows that timber chimneys were not purely an early sixteenth century phenomena as was once thought. Another feature we encountered as the project progressed was a number of crosswings, of which we gained three dated examples (Tacolneston Hall, 1618; St Mary's Farmhouse, 1628 and Old Manor Farmhouse, approx. 1600).

The journal makes this information available to villagers as well as to the general public (see the panel on page 2 giving details of how to acquire a Journal).

My enthusiasm for old buildings was rekindled when I joined the NHBG and made scale drawings of Chestnut

The meeting concluded with a presentation by Adam Longcroft, Chairman of NHBG, of a board outlining the key findings of the project, which was received by Dr Alan Mackie, Vice-Chairman of Tacolneston Parish Council and Secretary of TAFRA village hall, on behalf of the parish. The board is now displayed inside Tacolneston Village Hall.



Adam Longcroft, Chairman of NHBG, presents a permanent display board to Dr Alan Mackie, Vice-Chairman of Tacolneston Parish Council.

Norfolk Rural Schools Survey Susanna Wade-Martins

After our initial meeting at which a pro-forma and methodology was agreed, members of the survey group have been busy visiting schools and a few weeks ago we met to assess progress. Inevitably there were points for discussion. The first question was whether to record the present or past use. It was agreed that where a school had been converted there was no point in recording the modern use of various rooms and when it was possible to ascertain earlier uses, these should be noted. We had all been pleasantly surprised by the welcome we had received, both in schools still in use and those that were now in private ownership. Changes in school design over the period under study (c.1800-c.1950) are already becoming obvious. We plan to gather all our records together on a central database (at present Susanna's computer) and backed up on a memory stick, also at present with Susanna. We are still exploring various sources of grant aid and hope to publish our findings as a later volume of the NHBG Journal.

Our next meeting is planned for September 19th and is to be a field meeting looking at a few schools in the North Elmham area finishing with tea and buns at Susanna's.

More members of the group are always welcome and any one who would like to join the e-mailing list and so receive the final details for the day should contact Susanna at:

scwmartins@hotmail.com

**Next meeting:
September 19th 2009 at
North Elmham.
A field trip with tea and buns...**



The attractive early nineteenth century church school at Welborne, now used as a community Hall.



An unusual example of a new school built during the First World war at Swanton Morley demonstrating the value placed on light and fresh air as part of the educational philosophy of the time.

New NHBG Website. www.NHBG.org.uk

A new website for the Norfolk Historic Buildings Group is being developed and should be accessible by the end of September. We are hoping that this site will improve communication with our members, encourage new people to join us and act as a reference for students of historic buildings.

There will be three phases to the roll out of the site:

- The first phase will allow access to information concerning the Group, our aims and objectives, events, both past and future and details on how to join us.
- The second phase will involve the creation of a database

of all the buildings we have surveyed in Norfolk. This information will be accessible with due respect for the owners' privacy. It is hoped that this pool of information will grow over the years to become a comprehensive reference for the development of Norfolk as a county physically, financially and socially.

- The third phase will be the addition of all the information gathered concerning the places of worship in Norfolk.

As you can appreciate this will all take some time, but we are confident that each phase will add to the enjoyment of the group and make an easy reference to the historic buildings of Norfolk.

A Digest of Buildings Visited Since March 2009

This is a digest of all the Norfolk houses (excluding New Buckenham) which the NHBG has been invited to look at and prepare brief reports on. These are ALL private houses and NO contact may be made with the owners in any way except through the Committee. This list is to inform members of the work undertaken on behalf of the Group, and will not be printed on the Internet.

The reason for the brevity of the list is the work that has had to be undertaken by recorders on the completion and presentation of the Tacolneston Project. However, houses are being viewed and if you know of any suitable properties then please talk to Susan Brown. Ed.

1 and 3 High Street, Little Walsingham

A two cell building of about 1600 with a masonry ground floor and timber framed first floor. A queen post roof. Some remains of wall painting on the first floor.

Sunnydene, Sow's Row, Neatishead

Originally a single two cell dwelling with brick and flint to the front and clay/cob to the rear (see report in this Newsletter).

1 Church Street, Diss

A 16th/17th timber framed house. Possibly built as a tripartite house, altered to a lobby entrance and with a later brick front. Backhouse to the rear, probably contemporary to the first build.

Newsletter Request

Please do not forget that we are always looking for articles, items of interest, queries, photographs, or anything which has taken your interest to include in newsletters.

Alayne Fenner: 01603 452204
Rosemary Forrest: 01603 742315

Annual General Meeting

Following a tour of Beccles and the Museum building itself, the rain just held off and allowed 49 people to sit on the lawn at the Museum overlooking the Waveney marshes and consume large quantities of tea and scones.

The meeting was mercifully short - the Chairman thanked everybody for their support for the group which has a healthy (at least in terms of numbers) membership and finances. As there were no other nominations for the posts up for election, Ian Hinton was re-elected as Membership Secretary and the current committee re-elected en bloc. (The reason the Membership Secretary is an elected post is that at the beginning it was decided that all posts that handle money should be regularly elected)

It was announced that Alice Leftley had resigned her role as the Group's Publicity Officer. Adam thanked her for her sterling work, and asked that anyone interested in taking up this role should contact him.

Leman House Gardens, Beccles: Remains of the scones 'n' cream and before the drinks 'n' nibbles!



Gressenhall History Day May2009

NHBG Committee

Flying the Flag for NHBG



Three members of the Committee attended the History Fair at Gressenhall and took along various materials promoting the Group. It proved to be a wonderful opportunity to meet a wide range of people involved in historical research and those who are simply interested. On the buildings side we met thatchers and millwrights, Blue Badge Guides, Heritage Groups, publishers and possibly houses to visit.

The committee would be interested to hear from any member who would be willing to become more involved on the publicity and public relations side of the Group. This work could involve as much as a willing person would be willing to give but should cover the distribution of event posters, reports to the local press and other interested groups.

Please contact any of the committee members opposite and talk to them about your interest.

Book List

Richard Hewlings, Ed., *English Heritage Historical Review*, Vol. 3, 2008. Latest historical research about and interpretation of English Heritage properties.

Clare Hartwell, *Lancashire: North: The Buildings of England*, Pevsner Architectural Guides, April 2009.

Matthew Rice, *Building Norfolk*, Frances Lincoln, London, 2008



Members enjoying the scones and the nibbles at Leman House before and after the AGM.

Adam Longcroft *Chairman/Journal Editor*
Education and Lifelong Learning, UEA, Norwich, NR4 7TJ
01603 592 261 [w] *e.mail:* a.longcroft@uea.ac.uk

Alayne Fenner *Deputy Chairman/Newsletter Editor*
24 Mount Pleasant, Norwich, NR2 2DG
01603 452204 *e.mail:* alayne.fenner@btinternet.com

Lynne Hodge *Committee Secretary*
Tannery House Worthing, Dereham NR20 5RH
01362 668847 *e.mail:* lynne@walknorfolk.co.uk

Sue Shand *Treasurer*
Tibenham Farm, Long Row, Tibenham, Norwich NR16 1PD
e.mail: sushand@hotmail.co.uk

Ian Hinton *Membership Secretary*
The Old Rectory, Barnby, Beccles, NR34 7QN
01502 475 287 *e.mail:* ian.hinton@tesco.net

Michael and Sue Brown *Buildings*
Woodlands, Bylaugh Park, Dereham NR20 4RL
01362 688 362

Mary Ash *Winter Programme/Publications*
107 St Leonards Road, Norwich, NR1 4JF
01603 616285 *e.mail:* mary.ash@ntlworld.com

Dominic Summers *Summer Events*
17 Alan Road, Norwich, NR1 2BX
01603 663554 *e.mail:* d.summers1@btinternet.com

Rosemary Forrest *Newsletter*
3 Highlands, Costessey, NR8 5EA
01603 742 315 *e.mail:* forrest.rosemary@gmail.com

Richard Coulton
Little Ketlam, Low Road, Pentney, King's Lynn PE32 1JF
01553 691 661

Karen Mackie
44 Norwich Road, Tacolneston NR16 1BY
01508 488467 *e.mail:* karen_mackie@btinternet.com

Jackie Simpson *Web Page*
The Chestnuts, Church Road, Neatishead, Norfolk
01692 630639 *e.mail:* jackie.g.simpson@btinternet.com

Diane Barr *Documentary Research*
24 The Shrublands, Horsford, NR10 3EL
01603 898928 *e.mail:* di.barr@btinternet.com



Late News in case the Newsletter is out in time!

Recording a Timber-framed Building Saturday 12th September 2009

Two of our members have kindly offered their house in Pulham St Mary to be recorded as a training exercise on Saturday September 12th 2009.

Only by engaging in the whole process do you begin to see the complexities of understanding a building so do please take advantage of this opportunity...

You will be expected to complete a measured scale drawing in pencil. Your drawing will be part of the building (not the whole thing!) and it is hoped to be able to assemble these parts into a complete elevation or section of the house. Everyone will get a copy of the finished drawings and comments aimed at helping you to record more houses in the future.

Meet at 10.00 am and expect to finish by 4.00 pm.

You will need to bring some basic equipment and your lunch. Drawing boards, tapes and paper etc will be provided.

Sorry for short notice but please ring Susan Brown on 01362 688362 to book your place.

A great day out in King's Lynn!

East Anglia Building Conservation Fair

SPAB

(Society for the Protection of Ancient Buildings)

Saturday 19th September 2009

10.00 am — 5.00 pm

St Nicholas' Chapel

St Ann's Street, King's Lynn

Talks; Guided Walks; Demos of traditional building techniques; Information and Exhibitions

Admission Free

For more details contact John Selby at
john.selby@west-norfolk.gov.uk

or just turn up!



St Peter's House, Beccles. The round, white apsidal-shaped end is the transept end of the early church. (see Beccles Day, p. 6)

Winter Events 2009/2010

Please note that this season's meetings will take place in the new INTO building at the Bluebell Road end of University Drive, University of East Anglia. Entrance is off either Bluebell Road or Earlham Road (B1108), Norwich. Parking and facilities should be better, and we have managed to negotiate free use of the lecture hall.

The final lecture of the winter will be in King's Lynn, at The Green Quay, NOT Thoresby College as in previous years.

We look forward to welcoming members and guests to what we hope will be a varied and stimulating programme. As before, we begin the evening with drinks and nibbles from 7.00pm, and talks will start at 7.30pm.

Mary Ash
107 St Leonards Road
Norwich NR1 4JF
01603 616285
e.mail: 616284

The Norfolk Historic Buildings Group wishes to make it clear that Risk Assessments have been carried out for all visits, and where special equipment or care are required, applicants will be informed. Those attending events are responsible both for themselves and towards other members of the group.

Wednesday 14 October Professor Richard Wilson: Sir John Soane in Norfolk.

Richard Wilson is Emeritus Professor of Economic and Social History at UEA, and co-editor of the two recent volumes, 'Medieval Norwich' and 'Norwich Since 1550.' He is also co-author of 'The Building of the English Country House'.

Thursday 3 December: Dale Copley: Norfolk's Stained Glass.

Dale Copley is the Centre Manager of the recently-opened Hungate Medieval Art, previously the Hungate Museum, housed in St Peter Hungate Church in Norwich. The Centre currently focuses on Norfolk's amazing heritage of stained glass.

Thursday 11 February 2010: Dr Adam Longcroft: Medieval Towns of the Croatian Riviera.

Adam, as founder and current Chair of the NHBG, needs no introduction. His recent editing of, and introductory essay to The Tacolneston Project: NHBG Journal Volume 4 brings together the work of our recorders over the past three years in a most successful publication. His present research is taking him further afield...

Thursday 5 November David Martin: Houses of the Sussex Cinque Ports.

David Martin lectures at the University College of London's Institute of Archaeology, and is the senior Historic Buildings Officer for Archaeology South-East. His advice on the interpretation and restoration of historic buildings is much sought-after, and his current research into buildings of the Cinque Ports should prove fascinating.

Wednesday 20 January 2010 Members' Evening:

to include short talks on Buildings in Market Places, the new NHBG Website, an update on the Norfolk Rural Schools Project, and a current Report from the Churches Group. Contributions from other members welcome.

Wednesday 31 March 2010

Dr Paul Richards: Kings Lynn Merchant Houses and Warehouses 1400-1800.

Paul Richards, 'Mr Lynn', is well-known to NHBG members as the ultimate authority on all things to do with Kings Lynn. He has taken us on two or three wonderfully interesting walks around Lynn, but this is, I think, his first evening lecture for us. Apropos the title, he says, 'Houses invaded warehouses and vice versa!' and with our modern architect-designed warehouse apartments it's happening again. Please note this talk will take place at The Green Quay, South Quay, King's Lynn, another of Lynn's medieval warehouses.

Remember!
Meet at the new INTO building, University of East Anglia. It is sited at the Bluebell Road end of the Campus.
In King's Lynn the meeting will be at The Green Quay on South Quay.